

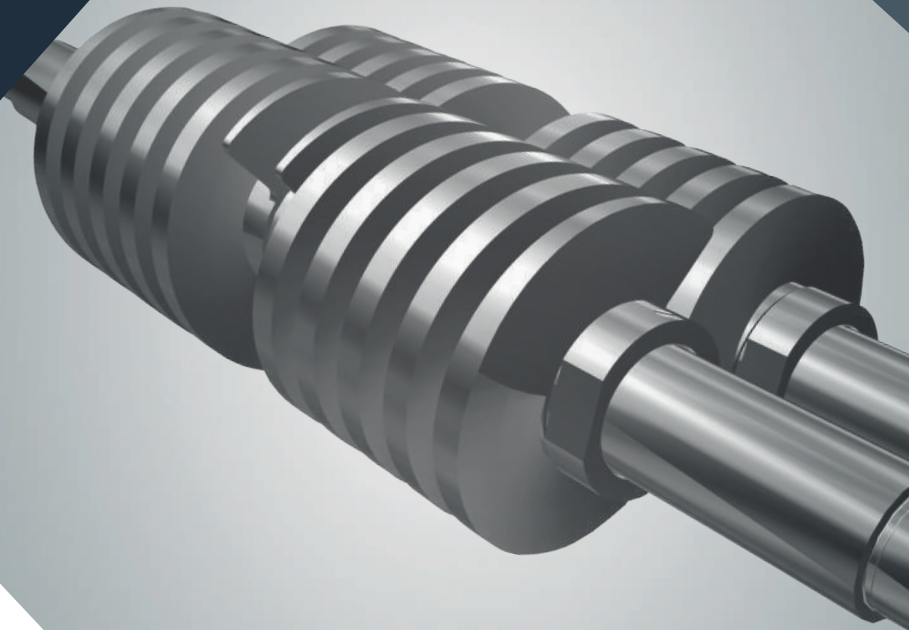

Bornemann Pumps and More Introducing a Global System Partner



ITT

ENGINEERED FOR LIFE

ITT Bornemann - The Pump Pioneer

About Bornemann

Founded in 1853, German-based Bornemann has achieved and secured a leading position worldwide with its numerous ground-breaking pump developments over the decades. Besides oil & gas, several industries are served, i.e. chemical, petrochemical and marine as well as food & pharmaceutical applications. Systematic research and development are leading to innovative solutions for the future.

About ITT

ITT is a diversified leading manufacturer of highly engineered critical components and customized technology solutions for the energy, transportation and industrial markets. Building on its heritage of innovation, ITT partners with its customers to deliver enduring solutions to the key industries that underpin modern way of life. Founded in 1920, ITT is headquartered in White Plains, N.Y., with employees in more than 35 countries and sales in a total of approximately 125 countries.

Customer Satisfaction as Part of the Company Strategy

Fair and constructive cooperation with clients, employees and suppliers is essential to our strategy and represent the foundation of the company culture. Bornemann's policy is to be an innovative, qualified and reliable partner to its customers, every step of the way, while providing a truly unique service. The needs of our customers are the focus of our research and development, manufacturing, sales and service.

Product quality, reliability and competent services are the decisive factors for customer satisfaction. From the very beginning of the installation, Bornemann Pumps and Systems are accompanied by capable services. ITT Bornemann's Service Team provides individually tailored consultation, documentation, delivery of spare parts, maintenance, repair, retooling, exchange, general overhaul, and more. Wherever in the world Bornemann Pumps and Systems are in use, Bornemann services are available.



Onshore Terminal in India

Unique Technologies

Customized Reliability

With the benefit of more than 80 years proven experience, Bornemann offers customized performance solutions for every operation. In-house design, production and 100 % workshop testing guarantee the high performance technology – essential for all addressed industries.

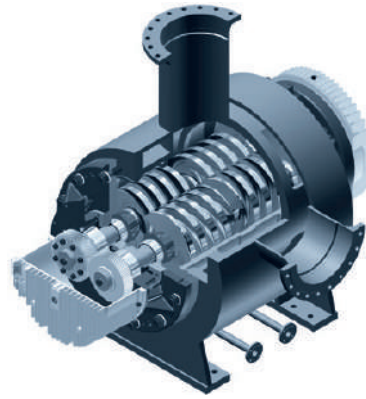

Bornemann Twin Screw Pump

Design & Performance

Bornemann Twin Screw Pumps are highly refined versions of the positive displacement principle, employing patented machining processes for the screw manufacture. Performance is a function of screw diameter, pitch and speed. In addition, there are special screw geometries available to give further efficiency savings of up to 25 %.

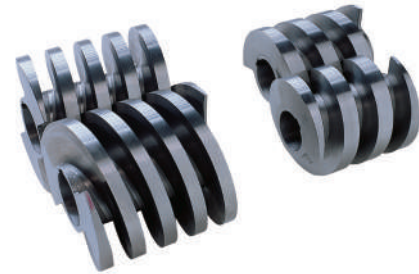

Bornemann Screw Design



Multiphase „Boosting in Libya“

Industries & Applications

Oil and Gas

Bornemann Twin Screw Pumps are ideal for pumping mixtures of crude oil, gas, water and solids. They can be used onshore and offshore. Dry running capabilities also allow the presence of gases. Compact design and special screw profiles allow high Δp for operation in pipelines with long distances.

Product Application:

Multiphase & crude oil transport, thermal operations, wet gas compression, oil & chemical storage.



Petrochemical Industry / Refinery

Bornemann Twin Screw Pumps transport low & high viscous products within terminals & refineries. All kinds of fluids, neutral, alkaline or acid and aggressive, abrasive or gaseous, are primed up safely, metered and pumped.

Product Application:

Mazut, bitumen, tar, heavy fuel, naphtha and chemical product



Marine

Bornemann Twin Screw Pumps have proven their value internationally as loading and transfer pumps on tankers, transfer pumps for heavy-duty HFO qualities and as lubricating pumps for main engine supply.

Product Application:

Bitumen, tar, light and heavy fuel oil, crude oil, mazut, chemicals & storage water



Chemical & General Industry

Regardless of low or high viscosity, aggressive, solid or shear-sensitive – twin screw pumps from Bornemann are used in any kind of chemical process. All Bornemann pumps are self-priming and ATEX-compliant.

Product Application:

Polymers, paints, slurry, pastes, liquid sulfur, and process chemicals



Hygienic Industry

Bornemann SLH-series has particularly been developed for applications in the Hygienic Industry. The 2-in-1 principle conveys and cleans in one pump.

Product Application:

Beverages, dairy products, convenience, sweets, meats, personal care, cosmetics, pharmaceuticals



Bornemann Twin Screw Pump Series

Twin Screw Pumps

Bornemann Twin Screw Pumps are rotating positive displacement pumps; the gearwheels and roller bearings are located externally without contact to the process liquid. More than 80 models are available with various materials, sizes and designs for application-optimized solutions.

Bornemann pumps cover a wide range of performances in pressure, flow, temperature and viscosity of the conveyed products, i.e. thin liquids such as petrol, hydrocarbons, seawater, liquids with high viscosity such as bitumen, tar, glue, molasses, and aggressive media such as acids and bases as well as multiphase mixtures.

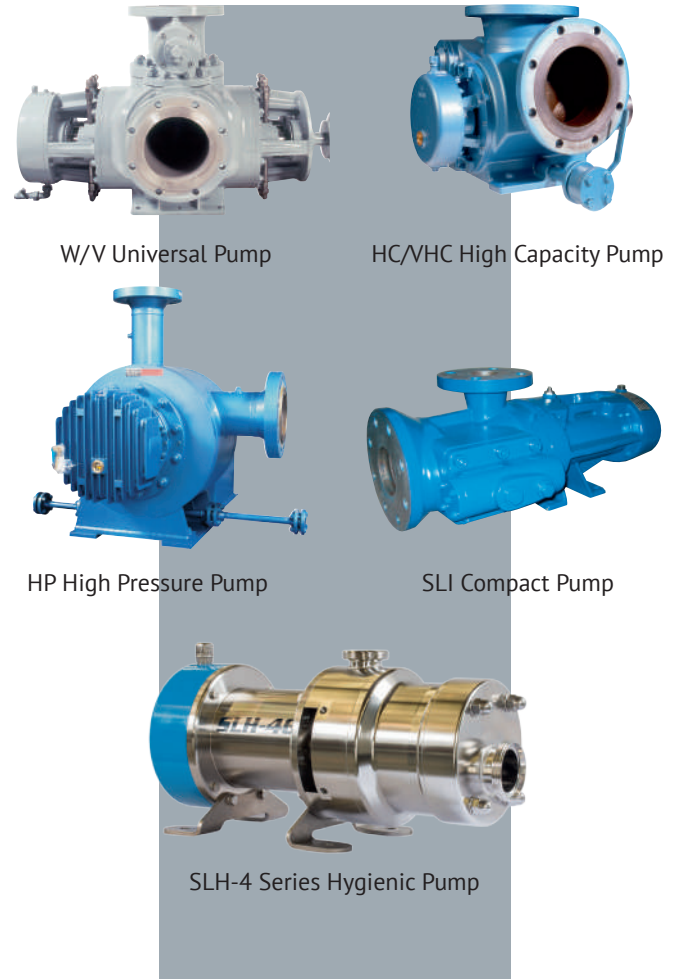

User Advantages

- Self-priming
- Safe operation at high viscosities
- Low pulsations
- Low noise level
- Dry running possible
- Constant flow at varying pressures and volumes
- Suction lift up to 8.5 m (25 feet)

	Capacity		Differential Pressure		Viscosity		Max. Product Temperature	
	m ³ /h	gpm	bar	psi	mm ² /s	cSt	°C	°F
W/V Universal Pump	10 - 2,800	50 - 12,300	up to 40/60	up to 600/900	0,5 - 200,000		up to 350	up to 660
HC/VHC High Capacity Pump	up to 4,500	up to 19,800	up to 16	up to 230	1 - 20,000		up to 120	up to 250
HP High Pressure Pump	20 - 1,500	100 - 6,600	up to 100	up to 1,500	1 - 10,000		up to 120	up to 250
SLI Compact Pump	up to 180	up to 790	up to 16	up to 230	up to 100,000		up to 120	up to 250
SLH-4 Series Hygienic Pump	up to 300	up to 1,600	up to 25	up to 360	up to 1,000,000		up to 180	up to 350

Bornemann Multiphase Systems



MSL Single Well Multiphase Pump



SLM Single Line Multiphase Pump

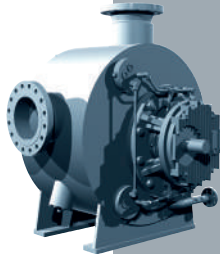

MW Classic Multiphase Pump



MPC Multiphase Pump Compressor

Multiphase Pumping Systems

Highly experienced in research & development, engineering, production and commissioning all over the world, Bornemann is able to supply complete system solutions - for a wide range of performance parameters and harsh ambient environmental conditions.

„Plug and Pump“

The skid mounted pump is equipped with all required instrumentation, piping and valves for safe operation. Operators are getting complete systems incl. electrical drive, variable frequency converter and control system. It will undergo a complete system factory acceptance test prior to shipment, thus saving time while commissioning.

	Capacity		Differential Pressure		Viscosity		Max. Product Temperature	
	m ³ h	BPD	bar	psi	mm ² /s	cSt	°C	°F
MSL Single Well Multiphase Pump	1 - 110	137 - 16,800	up to 16	up to 230	0,5 - 100,000		up to 160	up to 320
SLM Single Line Multiphase Pump	1 - 130	150 - 20,000	up to 16	up to 230	0,5 - 100,000		up to 100	up to 210
MW Classic Multiphase Pump	1 - 8,000	up to 1,206,000	up to 50	up to 725	0,5 - 100,000		up to 160	up to 320
MPC Multiphase Pump Compressor	1 - 8,000	up to 1,206,000	up to 110	up to 1,600	0,5 - 100,000		up to 160	up to 320

Selected Applications

Tank Terminals

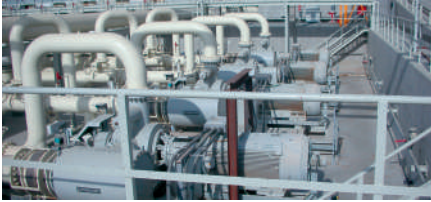

Country: U.A.E.
 Pump Type: W9
 Medium: Fuel oil, 55°C/130°F, 380cSt
 Capacity: 120-1,400 m³h
 530-6,200 gpm
 Pressure: 10 bar / 145 psi
 Speed: 200-1,470 rpm
 Shaft Power: 95-630 kW / 128-848 HP

Marine



Country: China
 Pump Type: W7
 Medium: Crude oil, 85°C/185°F, 130cSt
 Capacity: 210 m³h / 950 gpm
 Pressure: 8 bar / 120 psi
 Speed: 1,450 rpm
 Shaft Power: 70 kW / 95 HP

Refinery



Country: Germany
 Pump Type: W7T
 Medium: Bitumen, 220-250°C/ 430-480°F, 350 cSt
 Capacity: 110-240-370 m³h
 480-1,060-1,600 gpm
 Pressure: 11 bar / 160 psi
 Speed: 600-1,200-1,800 rpm
 Shaft Power: 190 kW / 256 HP

Oil Production

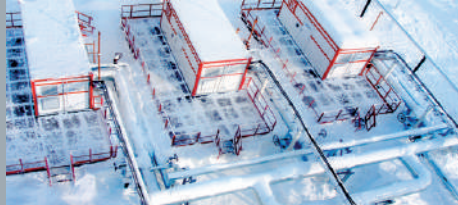

Country: Russia
 Pump Type: MPC 208
 Medium: Fluid Multiphase Mixture
 Capacity: up to 500 m³h
 75,757 BPD
 Pressure: 21 bar / 305 psi
 Speed: 2,000 rpm
 Shaft Power: 276 kW / 370 HP
 Gas content: 96 %

Offshore



Country: Germany
 Pump Type: MPC 268
 Medium: Fluid Multiphase Mixture
 Capacity: 610 m³h/2,686 gpm
 Pressure: 25 bar / 363 psi
 Speed: 1,765 rpm
 Shaft Power: 450kW / 612 HP
 Gas Content: 99 %

Chemical

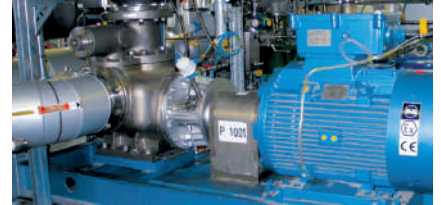

Country: Germany
 Pump Type: W7
 Medium: Water, solvent, silicon acrylate, polyether
 20-130°C / 70-270°F,
 1-15,000 cSt
 Capacity: 4-100 m³h
 Pressure: 1-5 bar / 14-73 psi
 Speed: 300-1,400 rpm
 Shaft Power: 55 kW / 74 HP

ITT Bornemann - Worldwide

Europe, Middle East, Africa

ITT Bornemann GmbH
Industriestrasse 2
31683 Obernkirchen
GERMANY
Tel: +49 5724 390-0
Fax: +49 5724 390-290
info.bornemann@itt.com
www.bornemann.com



Germany – Headquarters

North America

ITT Goulds Pumps Inc.
12510 Sugar Ridge Blvd
77477 Stafford, TX
UNITED STATES OF AMERICA
Tel: +1 281 504 6300
Fax: +1 281 504 6399
info.bornemann@itt.com
www.bornemann.com

Latin America

ITT Argentina - Bombas Bornemann
Mariano Moreno 4380
Munro
B 1605BOF
Prov. Buenos Aires
ARGENTINA
Tel: +54 11 4756 8008
Fax: +54 11 4756 5541
info.bornemann@itt.com
www.bornemann.com

Asia Pacific

ITT Fluid Technology Asia Pte. Ltd.
1 Jalan Kilang Timor #04-06
Singapore 159303
SINGAPORE
Tel: +65 6276 3693
Fax: +65 6276 3685
ipgsin@itt.com
www.bornemann.com

China

ITT Fluid Technology Co. Ltd.
Room 902, Tower A
No. 100 Zunyi Road
Changning District
Shanghai 200051
CHINA
Tel: +86 21 2231 2388
Fax: +86 21 2231 2308
info.bornemann@itt.com
www.bornemann.com

Australia

ITT Industrial Process
29 Paramount Drive
WANGARA, WA 6065
AUSTRALIA
Tel: +61 8 9302 1855
Fax: +61 8 9302 1856
info.bornemann@itt.com
www.bornemann.com

Russia

ITT IP- ITT Industries Rus LLC
125167 Leningradsky prospekt, 37A
building 14, 3rd floor
Moscow
RUSSIA
Tel: +7 495 223 0650
Fax: +7 495 223 0651
info.rus@itt.com
www.bornemann.com



ENGINEERED FOR LIFE

